



PRODUCT/PROCESS CHANGE NOTIFICATION

PCN MMS-MIC/14/8685
Dated 03 Oct 2014

**Conversion to High Density Matrix Leadframe - LQFP 64
10x10 products listed below**

Table 1. Change Implementation Schedule

Forecasted implementation date for change	10-Feb-2015
Forecasted availability date of samples for customer	10-Jan-2015
Forecasted date for STMicroelectronics change Qualification Plan results availability	10-Jan-2015
Estimated date of changed product first shipment	10-Feb-2015

Table 2. Change Identification

Product Identification (Product Family/Commercial Product)	LQFP 64 10x10 package products
Type of change	Assembly additional location
Reason for change	To increase assembly capacity
Description of the change	ST Microcontrollers Division has decided to add a High Density Matrix leadframe line in Muar (Malaysia) assembly site, for LQFP 64 10x10 products listed below. The objective is to increase assembly capacity. The assembly plants and Bill Of Materials are changed as indicated below.
Change Product Identification	See indicated below
Manufacturing Location(s)	

Table 3. List of Attachments

Customer Part numbers list	
Qualification Plan results	



Customer Acknowledgement of Receipt		PCN MMS-MIC/14/8685					
Please sign and return to STMicroelectronics Sales Office		Dated 03 Oct 2014					
<input type="checkbox"/> Qualification Plan Denied <input type="checkbox"/> Qualification Plan Approved <input type="checkbox"/> Change Denied <input type="checkbox"/> Change Approved	<table border="1" style="width: 100%; border-collapse: collapse;"> <tr><td style="padding: 2px;">Name:</td></tr> <tr><td style="padding: 2px;">Title:</td></tr> <tr><td style="padding: 2px;">Company:</td></tr> <tr><td style="padding: 2px;">Date:</td></tr> <tr><td style="padding: 2px;">Signature:</td></tr> </table>		Name:	Title:	Company:	Date:	Signature:
Name:							
Title:							
Company:							
Date:							
Signature:							
Remark							

DOCUMENT APPROVAL

Name	Function
Colonna, Daniel	Marketing Manager
Buffa, Michel	Product Manager
Narche, Pascal	Q.A. Manager



PRODUCT/PROCESS CHANGE NOTIFICATION

Conversion to High Density Matrix Leadframe – LQFP 64 10x10 products listed below

MMS - Microcontrollers Division (MCD)

Dear Customer,

ST Microcontrollers Division has decided to add a High Density Matrix leadframe line in Muar (Malaysia) assembly site, for LQFP 64 10x10 products listed below.

The objective is to increase assembly capacity.

What are the changes?

On LQFP 64 10x10 products listed below, the assembly plants and Bill Of Materials are as below:

Current		
Assembly site	Bill Of Materials (BOM)	
Muar (Malaysia)	Leadframe	PrePlated Frame (PPF)
	Die attached material	Hitachi EN4900
	Molding compound	Sumitomo G700F
	Wire	Gold 1.0mil
STATS ChipPAC Shanghai (China)	Leadframe	Pure Sn
	Die attached material	Ablestik 3230
	Molding compound	Sumitomo G700E
	Wire	Gold 0.8mils

New		
Assembly site	Bill Of Materials (BOM)	
Muar (Malaysia)	Leadframe	Pure Sn
	Die attached material	Hitachi EN4900GC
	Molding compound	Sumitomo G700LS
	Wire	Gold 0.8mils

Why ?

ST Microcontrollers Division add a LQFP 64 10x10 products on High Density Matrix leadframe line in Muar (Malaysia) assembly site, to increase assembly capacity.

When ?

The production on the new leadframe will start from week 07 2015.

How will the change be qualified?

This change will be qualified using the standard STMicroelectronics Corporate Procedures for Quality and Reliability, in full compliancy with the JESD-47 international standard. You can find below Qualification Plan.

What is the impact of the change?

- **Form:** no change
- **Fit:** no change
- **Function:** no change

How can the change be seen?

Traceability of the change is ensured by ST internal tools.

1/ For products listed below changing from STATS ChipPAC Shanghai (China) to Muar (Malaysia) assembly site:

The marking instruction indicated on the products is changing from:

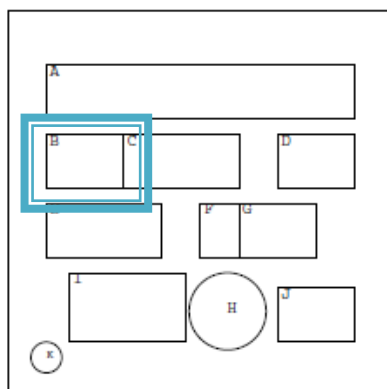

B : Assembly plant changes from GH to 99

2/ For products listed below remaining at Muar (Malaysia) assembly site:

The marking instruction indicated on the products is changing from:

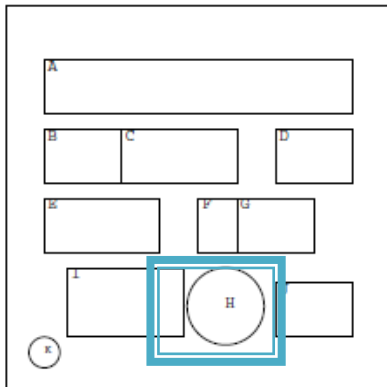

H : Second level interconnect changes from e4 to e3

We remain available to discuss any concern that you may have regarding this Product Change Notification.

With our sincere regards.

Michel Buffa

Microcontroller Division General Manager

Commercial products impacted:

Commercial Product	Assembly Plant	
	Current	New
STM32F100RCT6	STATS ChipPAC Shanghai (China)	Muar (Malaysia)
STM32F100RCT6TR	STATS ChipPAC Shanghai (China)	Muar (Malaysia)
STM32F101R8T6	Muar (Malaysia)	Muar (Malaysia)
	STATS ChipPAC Shanghai (China)	Muar (Malaysia)
STM32F101R8T6TR	Muar (Malaysia)	Muar (Malaysia)
	STATS ChipPAC Shanghai (China)	Muar (Malaysia)
STM32F101RBT6	Muar (Malaysia)	Muar (Malaysia)
	STATS ChipPAC Shanghai (China)	Muar (Malaysia)
STM32F101RBT6TR	Muar (Malaysia)	Muar (Malaysia)
	STATS ChipPAC Shanghai (China)	Muar (Malaysia)
STM32F101RCT6	STATS ChipPAC Shanghai (China)	Muar (Malaysia)
STM32F101RCT6TR	STATS ChipPAC Shanghai (China)	Muar (Malaysia)
STM32F101RDT6	STATS ChipPAC Shanghai (China)	Muar (Malaysia)
STM32F101RDT6TR	STATS ChipPAC Shanghai (China)	Muar (Malaysia)
STM32F101RDWOWTR	STATS ChipPAC Shanghai (China)	Muar (Malaysia)
STM32F101RET6	STATS ChipPAC Shanghai (China)	Muar (Malaysia)
STM32F102R8T6	STATS ChipPAC Shanghai (China)	Muar (Malaysia)
STM32F102RBT6	STATS ChipPAC Shanghai (China)	Muar (Malaysia)
STM32F102RBT6TR	STATS ChipPAC Shanghai (China)	Muar (Malaysia)
STM32F102RCT6	STATS ChipPAC Shanghai (China)	Muar (Malaysia)
STM32F103R8T6	Muar (Malaysia)	Muar (Malaysia)
	STATS ChipPAC Shanghai (China)	Muar (Malaysia)
STM32F103R8T6TR	Muar (Malaysia)	Muar (Malaysia)
	STATS ChipPAC Shanghai (China)	Muar (Malaysia)
STM32F103R8T7	STATS ChipPAC Shanghai (China)	Muar (Malaysia)
STM32F103RBT6	Muar (Malaysia)	Muar (Malaysia)
	STATS ChipPAC Shanghai (China)	Muar (Malaysia)
STM32F103RBT6TR	Muar (Malaysia)	Muar (Malaysia)
	STATS ChipPAC Shanghai (China)	Muar (Malaysia)
STM32F103RBT7	STATS ChipPAC Shanghai (China)	Muar (Malaysia)
STM32F103RBT7TR	STATS ChipPAC Shanghai (China)	Muar (Malaysia)
STM32F103RCT6	STATS ChipPAC Shanghai (China)	Muar (Malaysia)
STM32F103RCT6TR	STATS ChipPAC Shanghai (China)	Muar (Malaysia)
STM32F103RCT7	STATS ChipPAC Shanghai (China)	Muar (Malaysia)
STM32F103RCUVWTR	STATS ChipPAC Shanghai (China)	Muar (Malaysia)
STM32F103RDT6	STATS ChipPAC Shanghai (China)	Muar (Malaysia)
STM32F103RDT6TR	STATS ChipPAC Shanghai (China)	Muar (Malaysia)
STM32F103RET6	STATS ChipPAC Shanghai (China)	Muar (Malaysia)
STM32F103RET6TR	STATS ChipPAC Shanghai (China)	Muar (Malaysia)
STM32F103RET7	STATS ChipPAC Shanghai (China)	Muar (Malaysia)
STM32P101RCMBR	STATS ChipPAC Shanghai (China)	Muar (Malaysia)
STM8S207R6T6	Muar (Malaysia)	Muar (Malaysia)
	STATS ChipPAC Shanghai (China)	Muar (Malaysia)
STM8S207R6T6TR	Muar (Malaysia)	Muar (Malaysia)
	STATS ChipPAC Shanghai (China)	Muar (Malaysia)
STM8S207R8T3	Muar (Malaysia)	Muar (Malaysia)
	STATS ChipPAC Shanghai (China)	Muar (Malaysia)

STM8S207R8T3TR	Muar (Malaysia)	Muar (Malaysia)
	STATS ChipPAC Shanghai (China)	Muar (Malaysia)
STM8S207R8T6	Muar (Malaysia)	Muar (Malaysia)
	STATS ChipPAC Shanghai (China)	Muar (Malaysia)
STM8S207R8T6TR	Muar (Malaysia)	Muar (Malaysia)
	STATS ChipPAC Shanghai (China)	Muar (Malaysia)
STM8S207RBT3	Muar (Malaysia)	Muar (Malaysia)
	STATS ChipPAC Shanghai (China)	Muar (Malaysia)
STM8S207RBT3TR	Muar (Malaysia)	Muar (Malaysia)
	STATS ChipPAC Shanghai (China)	Muar (Malaysia)
STM8S207RBT6	Muar (Malaysia)	Muar (Malaysia)
	STATS ChipPAC Shanghai (China)	Muar (Malaysia)
STM8S207RBT6TR	Muar (Malaysia)	Muar (Malaysia)
	STATS ChipPAC Shanghai (China)	Muar (Malaysia)
STM8S208R8T6	Muar (Malaysia)	Muar (Malaysia)
	STATS ChipPAC Shanghai (China)	Muar (Malaysia)
STM8S208RBT3	Muar (Malaysia)	Muar (Malaysia)
	STATS ChipPAC Shanghai (China)	Muar (Malaysia)
STM8S208RBT6	Muar (Malaysia)	Muar (Malaysia)
	STATS ChipPAC Shanghai (China)	Muar (Malaysia)
STM8SP207R6MEY	Muar (Malaysia)	Muar (Malaysia)
	STATS ChipPAC Shanghai (China)	Muar (Malaysia)



RERMCD 1411 RELIABILITY PLAN

Qualification of :

**New BOM with High density leadframe LQFP10*10 at ST Muar
for Microcontrollers devices**

Qualification Reference:	RERMCD1411
Issued on:	Aug 11, 2014
Assembly Plant:	ST Muar
Assembly Line:	LQFP
Devices:	STM32/ STM8S
Package / Process:	10x10 (64 Leads)
Lead termination:	Pure Sn
Die attach:	Hitachi EN4900GC
Mold compound:	Sumitomo G700LS
Wire material/ diameter:	Gold 0.8mils
MSL:	MSL3

**Purpose**

Qualification of new BOM for LQFP10x10- 64 leads at ST Muar.

Test Vehicles :

Package	Device (Partial RawLine Code)	Diffusion Process fab	Number of Lots
LQFP 10x10 64 leads	STM32F (5W*410)	0.18µm- TSMC	1
	STM32F (5W*414)	0.18µm- TSMC	1
	STM8S (5W*765)	F9GO1- ST Rousset	1

Package Reliability Trials :

(*) tests performed after preconditioning

Reliability Trial		Test Conditions	Pass Criteria	Unit per Lot	Qual Lot nb
PC	Pre Conditioning: Moisture Sensitivity Jedec Level 3 J-STD-020/ JESD22-A113	Bake (125°C / 24 hrs) Soak (30°C / 60% RH / 192 hrs) for level 3 Convection reflow: 3 passes with Jedec level 3	3 passes MSL3	231	3
AC(*)	Autoclave JESD22 A102	121°C, 100% RH, 2 Atm	96h	77	3
TC(*)	Thermal Cycling JESD22 A104	-50°C, +150°C	1000Cy	77	3
WBP	Wire Bond Pull Mil Std 883 Method 2011		Minimum pull strength after TC=3 grams after TC	30 wires	3
WBS	Wire Bond Shear AEC Q100-001		Min bond shear 15g after TC	30 wires	3
THB(*)	Temperature Humidity Bias JESD22 A101	85°C, 85% RH, bias	1000h	77	3
HTSL	High Temperature Storage Life JESD22 A103	150°C- no bias	1000h	77	3
ESD	ESD Charge Device Model ANSI/ESDSTM5.3.1	500V	500V	3	All devices



Physical dimension	Dimension measurement		CPK >1.33	10	3
	JESD 22B100/B108		PPK >1.67		
Solderability	Lead solderability		>95% lead coverage	45 leads	3
	JESD 22B102				

Attachment : Reliability tests description

Package oriented tests/ Trials description

1. Preconditioning

According to ST spec 0098044.

Preconditioning test sequence simulates storage and soldering of SMD (surface mount devices) before submitting them to the reliability tests. It aims to validate the moisture sensitivity level of the package, and prepare it to the stress of additional reliability tests, thus enabling a good modeling of the life of the packaged product.

Out-of-bag floor life storage and soldering are modeled by the following test sequence:

- Bake to completely remove moisture from the package;
- Moisture soak according to the package moisture level;
- IR reflow.

The aim is to check that the chip and plastic package withstand the stress due to report on card. Depending on their technology, packages may absorb moisture during their transportation and/or storage, moisture that is released during the soldering operation. At this step, the moisture absorbed is vaporized due to high temperature of solder reflow process. This phenomenon can create plastic swelling, "pop corn" effect, and cracks which eventually results in wire breakage, passivation cracks, and delamination.

2. Autoclave (AC)

The device is stored in saturated steam, at fixed and controlled conditions of pressure and temperature.

Purpose: to investigate corrosion phenomena affecting die or package materials, related to chemical contamination and package hermeticity.

To point out critical water entry paths with consequent electrochemical and galvanic corrosion.

3. Temperature Cycling (TC)

The device is submitted to cycled temperature excursions, between a hot and a cold chamber in air atmosphere (thermal gradient typical 10 C/min).

Purpose: to investigate failure modes related to the thermo-mechanical stress induced by the different thermal expansion of the materials interacting in the die-package system.

Typical failure modes are linked to metal displacement, dielectric cracking, moulding compound delamination, wire-bonds failure, die-attach layer degradation.

4. Temperature Humidity Bias (THB)

The device is biased in static configuration minimizing its internal power dissipation, and stored at controlled conditions of ambient temperature and relative humidity.

The Temperature Humidity Bias follows the same method than HAST at lower temperature.

Purpose: to investigate failure mechanisms activated in the die-package environment by electrical field and wet conditions.

Typical failure mechanisms are electro-chemical corrosion and surface effects related to the molding compound.

The package moisture resistance with electrical field applied is verified, both electrolytic and galvanic corrosion are put in evidence.

Conditions:

- Ta=85°C; R.H.=85%;
- Power supply voltage less or equal to max operative voltage to not exceed Tj = 95 °C.

5. High Temperature Storage Life (HTSL)

The device is stored in unbiased condition at the max. temperature allowed by the package materials, sometimes higher than the max. operative temperature.

Purpose: to investigate the failure mechanisms activated by high temperature, typically wire-bonds solder joint ageing, data retention faults, metal stress-voiding.

6. ESD Charge Device Model (CDM)

This ESD failure model is associated with the device and package itself. The CDM is intended to simulate charging/discharging events that occur in production equipment and processes. The Field induced CDM equivalent circuit used to describe this phenomenon is illustrated in Figure 1.

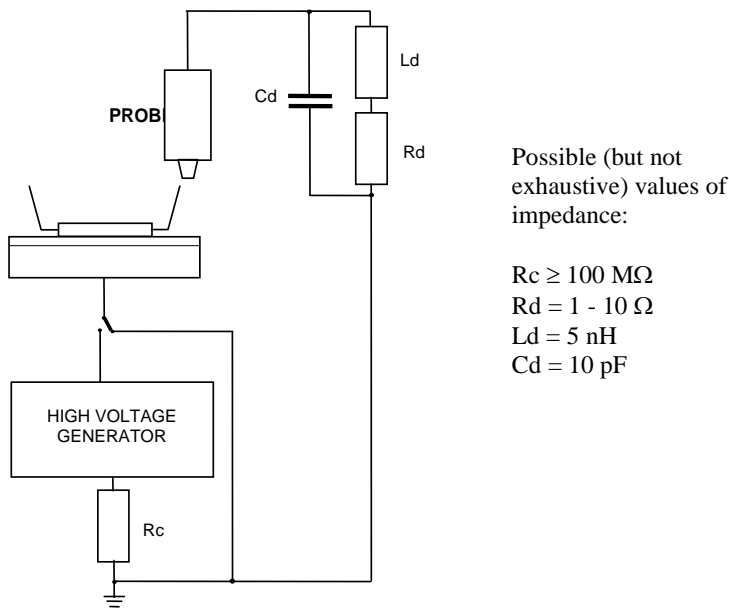

Fig.1 : Field induced CDM equivalent circuit

Please Read Carefully:

Information in this document is provided solely in connection with ST products. STMicroelectronics NV and its subsidiaries ("ST") reserve the right to make changes, corrections, modifications or improvements, to this document, and the products and services described herein at any time, without notice.

All ST products are sold pursuant to ST's terms and conditions of sale.

Purchasers are solely responsible for the choice, selection and use of the ST products and services described herein, and ST assumes no liability whatsoever relating to the choice, selection or use of the ST products and services described herein.

No license, express or implied, by estoppel or otherwise, to any intellectual property rights is granted under this document. If any part of this document refers to any third party products or services it shall not be deemed a license grant by ST for the use of such third party products or services, or any intellectual property contained therein or considered as a warranty covering the use in any manner whatsoever of such third party products or services or any intellectual property contained therein.

UNLESS OTHERWISE SET FORTH IN ST'S TERMS AND CONDITIONS OF SALE ST DISCLAIMS ANY EXPRESS OR IMPLIED WARRANTY WITH RESPECT TO THE USE AND/OR SALE OF ST PRODUCTS INCLUDING WITHOUT LIMITATION IMPLIED WARRANTIES OF MERCHANTABILITY, FITNESS FOR A PARTICULAR PURPOSE (AND THEIR EQUIVALENTS UNDER THE LAWS OF ANY JURISDICTION), OR INFRINGEMENT OF ANY PATENT, COPYRIGHT OR OTHER INTELLECTUAL PROPERTY RIGHT.

ST PRODUCTS ARE NOT DESIGNED OR AUTHORIZED FOR USE IN: (A) SAFETY CRITICAL APPLICATIONS SUCH AS LIFE SUPPORTING, ACTIVE IMPLANTED DEVICES OR SYSTEMS WITH PRODUCT FUNCTIONAL SAFETY REQUIREMENTS; (B) AERONAUTIC APPLICATIONS; (C) AUTOMOTIVE APPLICATIONS OR ENVIRONMENTS, AND/OR (D) AEROSPACE APPLICATIONS OR ENVIRONMENTS. WHERE ST PRODUCTS ARE NOT DESIGNED FOR SUCH USE, THE PURCHASER SHALL USE PRODUCTS AT PURCHASER'S SOLE RISK, EVEN IF ST HAS BEEN INFORMED IN WRITING OF SUCH USAGE, UNLESS A PRODUCT IS EXPRESSLY DESIGNATED BY ST AS BEING INTENDED FOR "AUTOMOTIVE, AUTOMOTIVE SAFETY OR MEDICAL" INDUSTRY DOMAINS ACCORDING TO ST PRODUCT DESIGN SPECIFICATIONS. PRODUCTS FORMALLY ESCC, QML OR JAN QUALIFIED ARE DEEMED SUITABLE FOR USE IN AEROSPACE BY THE CORRESPONDING GOVERNMENTAL AGENCY.

RESTRICTIONS OF USE AND CONFIDENTIALITY OBLIGATIONS:

THIS DOCUMENT AND ITS ANNEXES CONTAIN ST PROPRIETARY AND CONFIDENTIAL INFORMATION. THE DISCLOSURE, DISTRIBUTION, PUBLICATION OF WHATSOEVER NATURE OR USE FOR ANY OTHER PURPOSE THAN PROVIDED IN THIS DOCUMENT OF ANY INFORMATION CONTAINED IN THIS DOCUMENT AND ITS ANNEXES IS SUBMITTED TO ST PRIOR EXPRESS AUTHORIZATION. ANY UNAUTHORIZED REVIEW, USE, DISCLOSURE OR DISTRIBUTION OF SUCH INFORMATION IS EXPRESSLY PROHIBITED.

Resale of ST products with provisions different from the statements and/or technical features set forth in this document shall immediately void any warranty granted by ST for the ST product or service described herein and shall not create or extend in any manner whatsoever, any liability of ST.

ST and the ST logo are trademarks or registered trademarks of ST in various countries.

Information in this document supersedes and replaces all information previously supplied.

The ST logo is a registered trademark of STMicroelectronics. All other names are the property of their respective owners

© 2014 STMicroelectronics - All rights reserved.

STMicroelectronics group of companies

Australia - Belgium - Brazil - Canada - China - Czech Republic - Finland - France - Germany - Hong Kong - India - Israel - Italy - Japan - Malaysia - Malta - Morocco - Philippines - Singapore - Spain - Sweden - Switzerland - United Kingdom - United States of America

www.st.com

