

## GENERAL DESCRIPTION

The **XR21V1410** is an enhanced Universal Asynchronous Receiver and Transmitter (UART) with a USB interface. The USB interface is fully compliant to Full Speed USB 2.0 specification that supports 12 Mbps USB data transfer rate. The USB interface also supports USB suspend, resume and remote wakeup operations.

The XR21V1410 operates from an internal 48MHz clock therefore no external crystal/oscillator is required as in previous generation UARTs. With the fractional baud rate generator, any baud rate can accurately be generated using the internal 48MHz clock.

The large 128-byte TX FIFO and 384-byte RX FIFO of the XR21V1410 helps to optimize the overall data throughput for various applications. The automatic transceiver direction control feature simplifies both the hardware and software for half-duplex RS-485 applications. If required, the multidrop (9-bit) mode with automatic half-duplex transceiver control feature further simplifies typical multidrop RS-485 applications.

The XR21V1410 operates from a single 2.97 to 3.63 volt power supply and has 5V tolerant inputs. The XR21V1410 is available in a 16-pin QFN package.

The XR21V1410 uses the native OS CDC-ACM driver or a MaxLinear supplied custom driver. MaxLinear provides WHQL/HCK-certified software drivers for Windows XP, Vista, 7, 8, 8.1 and 10 as well as software drivers for Windows CE, Linux and Mac OS X. Full source code is available.

## APPLICATIONS

- Portable Appliances
- External Converters (dongles)
- Battery-Operated Devices
- Cellular Data Devices
- Factory Automation and Process Controls
- Industrial applications

## FEATURES

- USB 2.0 Compliant, Full-Speed (12 Mbps)
  - Supports USB suspend, resume and remote wakeup operations
- $\pm 5$  kV HBM ESD protection on USB data pins
- $\pm 2$  kV HBM ESD protection on all other pins
- Enhanced UART Features
  - UART data rates up to 12 Mbps
  - Fractional Baud Rate Generator
  - 128 byte TX FIFO
  - 384 byte RX FIFO
  - 7, 8 or 9 data bits
  - 1 or 2 stop bits
  - Odd, even, mark, space, or no parity
  - Automatic Hardware (RTS/CTS or DTR/DSR) Flow Control
  - Automatic Software (Xon/Xoff) Flow Control
  - Multidrop mode
  - Auto RS-485 Half-Duplex Control
  - Half-Duplex mode
  - Selectable GPIO or Modem I/O
- Internal 48 MHz clock
- Single 3.3V power supply
- 5V tolerant GPIO inputs
- 16-pin QFN package
- Virtual COM Port WHQL certified drivers
  - Windows XP, Vista, Win7 and Win8
  - Windows CE 4.2, 5.0, 6.0, 7.0
  - Linux
  - Mac

**FIGURE 1. XR21V1410 BLOCK DIAGRAM**

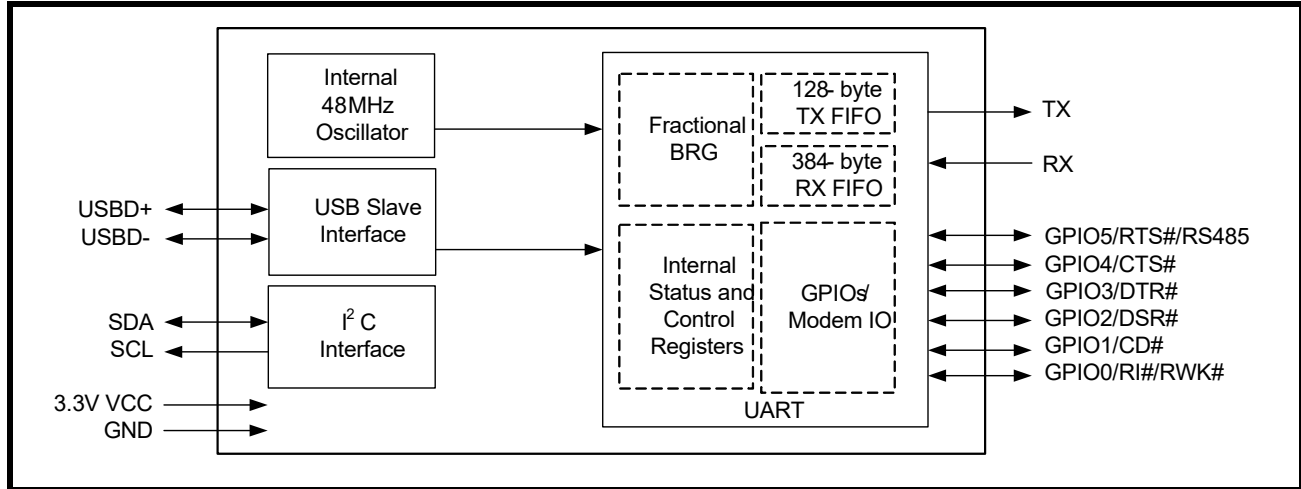

**FIGURE 2. PIN OUT ASSIGNMENT**

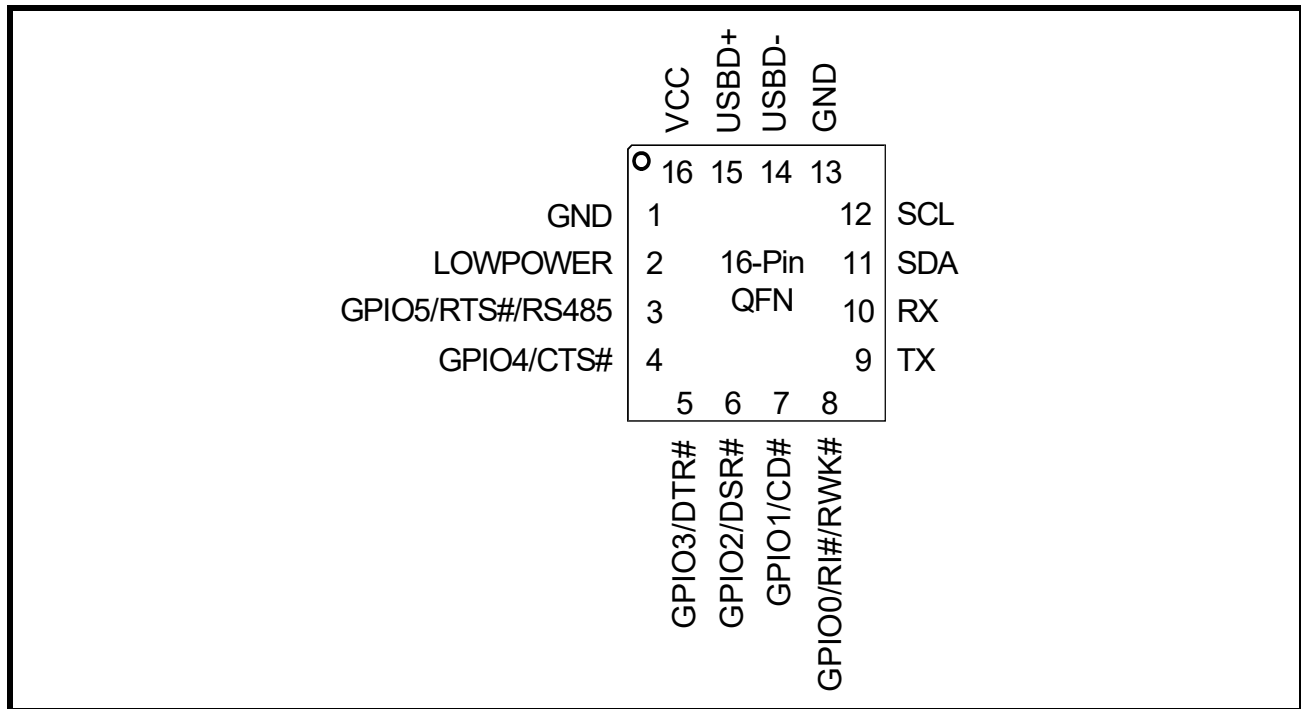

**ORDERING INFORMATION<sup>(1)</sup>**

PART NUMBER	OPERATING TEMPERATURE RANGE	LEAD-FREE	PACKAGE	PACKAGING METHOD
XR21V1410IL16-F	-40°C to +85°C	Yes <sup>(2)</sup>	16-pin QFN	Tray
XR21V1410IL16TR-F				Tape and Reel
XR21V1410IL-0A-EB	XR21V1410 Evaluation Board - RS-232 and RS-485 capable			
XR21V1410IL-0B-EB	XR21V1410 Evaluation Board - RS-232 capable			
XR21V1410IL-0C-EB	XR21V1410 Evaluation Board - RS-485 capable			

**NOTES:**

1. Refer to [www.exar.com/XR21V1410](http://www.exar.com/XR21V1410) for most up-to-date Ordering Information.
2. Visit [www.exar.com](http://www.exar.com) for additional information on Environmental Rating.

**PIN DESCRIPTIONS**

NAME	16-QFN PIN #	TYPE	DESCRIPTION
<b>UART Signals</b>			
RX	10	I	UART Channel A Receive Data. This pin has an internal pull-up resistor. Internal pull-up resistor is <u>not</u> disabled during suspend mode.
TX	9	O	UART Channel A Transmit Data.
GPIO0/RI#/RWK#	8	I/O	General purpose I/O or UART Ring-Indicator input (active low) or Remote Wakeup input. See <a href="#">"Section 1.5.13, Remote Wakeup" on page 11</a> . This pin has an internal pull-up resistor which is disabled during suspend mode. If using this GPIO as an input, an external pull-up resistor is required to minimize the device power consumption in the suspend mode.
GPIO1/CD#	7	I/O	General purpose I/O or UART Carrier-Detect input (active low). This pin has an internal pull-up resistor which is disabled during suspend mode. If using this GPIO as an input, an external pull-up resistor is required to minimize the device power consumption in the suspend mode.
GPIO2/DSR#	6	I/O	General purpose I/O or UART Data-Set-Ready input (active low). See <a href="#">"Section 1.5.6, Automatic DTR/DSR Hardware Flow Control" on page 9</a> . This pin has an internal pull-up resistor which is disabled during suspend mode. If using this GPIO as an input, an external pull-up resistor is required to minimize the device power consumption in the suspend mode.
GPIO3/DTR#	5	I/O	General purpose I/O or UART Data-Terminal-Ready output (active low). See <a href="#">"Section 1.5.6, Automatic DTR/DSR Hardware Flow Control" on page 9</a> . This pin has an internal pull-up resistor which is disabled during suspend mode. If using this GPIO as an input, an external pull-up resistor is required to minimize the device power consumption in the suspend mode.
GPIO4/CTS#	4	I/O	General purpose I/O or UART Clear-to-Send input (active low). See <a href="#">"Section 1.5.5, Automatic RTS/CTS Hardware Flow Control" on page 9</a> . This pin has an internal pull-up resistor which is disabled during suspend mode. If using this GPIO as an input, an external pull-up resistor is required to minimize the device power consumption in the suspend mode.
GPIO5/RTS#/RS485	3	I/O	General purpose I/O or UART Request-to-Send output (active low) or auto RS-485 half-duplex control. See <a href="#">"Section 1.5.5, Automatic RTS/CTS Hardware Flow Control" on page 9</a> or <a href="#">"Section 1.5.8, Auto RS-485 Half-Duplex Control" on page 10</a> . This pin has an internal pull-up resistor which is disabled during suspend mode. If using this GPIO as an input, an external pull-up resistor is required to minimize the device power consumption in the suspend mode.
<b>USB Interface Signals</b>			
USB+	15	I/O	USB port differential data plus. This pin has a 1.5 K Ohm internal pull-up.
USB-	14	I/O	USB port differential data minus.

NAME	16-QFN PIN #	TYPE	DESCRIPTION
<b>I<sup>2</sup>C Interface Signals</b>			
SDA	11	I/O OD	I <sup>2</sup> C-controller data input/output (open-drain). An optional external I <sup>2</sup> C EEPROM can be used to store default configurations upon power-up including the USB Vendor ID and Device ID. See <a href="#">Table 3</a> . A pull-up resistor (typically 4.7 to 10k Ohms) is required.  If an EEPROM is not used, this pin can be used with the SCL pin to select the Remote Wake-up and Power modes. An external pull-up or pull-down resistor is required. See <a href="#">Table 2</a>
SCL	12	I/O OD	I <sup>2</sup> C-controller serial input clock. An optional external I <sup>2</sup> C EEPROM can be used to store default configurations upon power-up including the USB Vendor ID and Device ID. See <a href="#">Table 3</a> . A pull-up resistor (typically 4.7 to 10k Ohms) is required.  If an EEPROM is not used, this pin can be used with the SDA pin to select the Remote Wake-up and Power modes. An external pull-up or pull-down resistor is required. See <a href="#">Table 2</a>
<b>Miscellaneous Signals</b>			
LOWPOWER	2	O	Low power status output. The LOWPOWER pin will be asserted whenever it is not safe to draw the amount of current from VBUS power requested in the Device Max Power field of the Configuration Descriptor. The LOWPOWER pin will behave differently for a low power device and a high power device. <ul style="list-style-type: none"> <li>• Low-power device (&lt;= 1 unit load or 100 mA i.e. bMaxPower &lt;= 0x32): LOWPOWER pin is asserted when the USB UART is in suspend mode.</li> <li>• High-power device (bMaxPower &gt; 0x32): LOWPOWER pin is asserted when the USB UART is in suspend mode or when it is not yet configured.</li> </ul> The LOWPOWER pin will be de-asserted whenever it is safe to draw the amount of current requested in the Device Maximum Power field. This pin is sampled momentarily at power-up or at any USB bus reset to configure the polarity of the LOWPOWER output during suspend mode. An external (10K) pull-up resistor will cause the LOWPOWER pin to be asserted HIGH during suspend mode. An external (3.3K) pull-down resistor will cause the LOWPOWER pin to be asserted LOW during suspend mode.
<b>Power / Ground Signals</b>			
VCC	16	Pwr	+3.3V power supply.
GND	1, 13	Pwr	Power supply common, ground.
GND	Center Pad	Pwr	The center pad on the back side of the QFN package is metallic and should be connected to GND on the PCB. The thermal pad size on the PCB should be the approximate size of this center pad and should be solder mask defined. The solder mask opening should be at least 0.0025" inwards from the edge of the PCB thermal pad.

**NOTE:** Pin type: I=Input, O=Output, I/O= Input/output, OD=Output Open Drain.

## 1.0 FUNCTIONAL DESCRIPTIONS

### 1.1 USB interface

The USB interface of the XR21V1410 is compliant with the USB 2.0 Full-Speed Specifications. The USB configuration model presented by the XR21V1410 to the device driver is compatible to the Abstract Control Model of the USB Communication Device Class (CDC-ACM). The XR21V1410 uses the following set of parameters:

- 1 Control Endpoint
  - Endpoint 0 as outlined in the USB specifications
- 1 Configuration is supported
- 2 interfaces for the UART channel
  - Single interrupt endpoint
  - Bulk-in and bulk-out endpoints

#### 1.1.1 USB Vendor ID

Exar's USB Vendor ID is 0x04E2. This is the default Vendor ID that is used for the XR21V1410 unless a valid EEPROM is present on the I<sup>2</sup>C interface signals. If a valid EEPROM is present, the Vendor ID from the EEPROM will be used.

#### 1.1.2 USB Product ID

The default USB Product ID for the XR21V1410 is 0x1410. If a valid EEPROM is present, the Product ID from the EEPROM will be used. Note that Exar's custom drivers for all Windows OS require that the Product ID be an even number for the XR21V1410 device for proper identification of the device.

### 1.2 USB Device Driver

The XR21V1410 device can be used with either a standard CDC-ACM driver or a custom driver. When the CDC-ACM driver is used, the driver has no capability to read or write the XR21V1410 device registers. Because of this, the XR21V1410 device is initialized to the settings in [Table 1](#). With a custom driver, all GPIOs default in hardware to inputs but these settings may be modified by the custom driver.

**TABLE 1: V1410 REGISTER DEFAULTS WITH CDC-ACM DRIVER**

REGISTER	VALUE	NOTES
FLOW_CONTROL	0x01	Hardware flow control
GPIO_MODE	0x01	RTS / CTS flow control
GPIO_DIRECTION	0x08	GPIO3/DTR# configured as an output
GPIO_INT_MASK	0x30	GPIO0/RI#, GPIO1/CD# and GPIO2/DSR# are interrupt sensitive, i.e. can cause a USB interrupt to be generated

Note also that when using a CDC-ACM driver, the XR21V1410 will automatically change the bMaxPacketSize to 63 bytes to compensate for a known issue with the Microsoft CDC-ACM device driver. A register is available to change this setting with a custom driver as well. See "[Section 3.4.1, CUSTOM Register Description \(Read/Write\)](#)" on [page 23](#). Although there is no ability to read / write registers when using the CDC-ACM driver, basic UART functions, including setting baud rate, character format and sending line break are supported by the CDC driver. Refer to the 4 CDC\_ACM\_IF USB Control Commands listed in [Table 4, "Supported USB Control Commands,"](#) on [page 12](#).

### 1.3 I<sup>2</sup>C Interface

The I<sup>2</sup>C interface provides connectivity to an external I<sup>2</sup>C memory device (i.e. EEPROM) that can be read by the XR21V1410 for configuration. If no external EEPROM is present, the SDA and SCL are used to specify remote wakeup support and power mode as described in Table 2. These pins are sampled at power-up.

TABLE 2: REMOTE WAKEUP AND POWER MODES

SDA	SCL	REMOTE WAKE-UP SUPPORT	POWER MODE
1	1	No	Self-Powered
1	0	No	Bus-Powered
0	1	Yes	Self-Powered
0	0	Yes	Bus-Powered

#### 1.3.1 EEPROM Contents

If SDA and SCL are both logic '1', the XR21V1410 device will first confirm if there is an external EEPROM attached by attempting to read the first 8 locations of the ROM. If address 0x07 of the ROM contains the value 0x58 (as specified in Table 3), the contents of the ROM are assumed to be valid. Otherwise the EEPROM will be ignored and the SDA / SCL bits are used to indicate remote wakeup support and device power mode.

The I<sup>2</sup>C address must be 0xA0. An EEPROM can be used to override default Vendor IDs and Device IDs, as well as other attributes and maximum power consumption. MaxLinear provides an in-circuit EEPROM programming utility through the USB interface using UART Control block 0x65. Refer to Table 5, "Control Blocks," on page 13. The EEPROM programming utility can be downloaded from the Exar website. These values are uploaded from the EEPROM to the corresponding USB Standard Device Descriptor or Standard Configuration Descriptor. For details of the USB Descriptors, refer to the USB 2.0 specifications.

TABLE 3: EEPROM CONTENTS

EEPROM ADDRESS	CONTENTS
0	Vendor ID (LSB)
1	Vendor ID (MSB)
2	Product ID (LSB)
3	Product ID (MSB)
4	Device Attributes
5	Device Maximum Power
6	Reserved
7	Signature of 0x58 ('X'). If the signature is not correct, the contents of the EEPROM are ignored.

##### 1.3.1.1 Vendor ID

The Vendor ID value replaces the idVendor field in the USB Standard Device Descriptor.

##### 1.3.1.2 Product ID

The Product ID value replaces the idProduct field in the USB Standard Device Descriptor.

### 1.3.1.3 Device Attributes

The Device Attributes value replaces the `bmAttributes` field in the USB Standard Configuration Descriptor. The default setting in the XR21V1410 device is 0xA0. The bit field definitions are:

- Bit 7 is reserved - set to '1'
- Bit 6 is Self-powered mode - set to '0' for bus-powered, set to '1' for self-powered
- Bit 5 is Remote Wakeup support - set to '0' for no support, set to '1' for remote wakeup support
- Bit 4:0 are reserved - set to '0'

### 1.3.1.4 Device Maximum Power

The Device Maximum Power value replaces the `bMaxPower` field in the USB Standard Configuration Descriptor. The value specified is in units of 2 mA. For example, the value 0x2F is decimal 47 or 94 mA. Note that the default `bMaxPower` of the XR21V1410 device is 94 mA.

## 1.4 UART Manager

The UART Manager enables/disables the UART including the TX and RX FIFOs. The UART Manager is located in a separate register block from the UART registers.

## 1.5 UART

The UART can be configured via USB control transfers from the USB host. The UART transmitter and receiver sections are described separately in the following sections. At power-up, the XR21V1410 will default to 9600 bps, 8 data bits, no parity bit, 1 stop bit, and no flow control. If a standard CDC driver accesses the XR21V1410, defaults will change. See "Section 1.2, USB Device Driver" on page 5.

### 1.5.1 Transmitter

The transmitter consists of a 128-byte TX FIFO and a Transmit Shift Register (TSR). Once a bulk-out packet has been received and the CRC has been validated, the data bytes in that packet are written into the TX FIFO of the specified UART channel. Data from the TX FIFO is transferred to the TSR when the TSR is idle or has completed sending the previous data byte. The TSR shifts the data out onto the TX output pin at the data rate defined by the `CLOCK_DIVISOR` and `TX_CLOCK_MASK` registers. The transmitter sends the start bit followed by the data bits (starting with the LSB), inserts the proper parity-bit if enabled, and adds the stop-bit(s). The transmitter can be configured for 7 or 8 data bits with or without parity or 9 data bits without parity. If 9 bit data is selected without wide mode, the 9th bit will always be '0'.

#### 1.5.1.1 Wide Mode Transmit

When both 9 bit data and wide mode are enabled, two bytes of data must be written. The first byte that is loaded into the TX FIFO are the first 8 bits (data bits 7-0) of the 9-bit data. Bit-0 of the second byte that is loaded into the TX FIFO is bit-8 of the 9-bit data. The data that is transmitted on the TX pin is as follows: start bit, 9-bit data, stop bit. Use the `WIDE_MODE` register to enable wide mode.

### 1.5.2 Receiver

The receiver consists of a 384-byte RX FIFO and a Receive Shift Register (RSR). Data that is received in the RSR via the RX pin is transferred into the RX FIFO. Data from the RX FIFO is sent to the USB host in response to a bulk-in request. Depending on the mode, error / status information for that data character may or may not be stored in the RX FIFO with the data.

#### 1.5.2.1 Normal receive operation with 7 or 8-bit data

Data that is received is stored in the RX FIFO. Any parity, framing or overrun error or break status information related to the data is discarded. Receive data format is shown in Figure 3.

#### 1.5.2.2 Normal receive operation with 9-bit data

The first 8 bits of data received is stored in the RX FIFO. The 9th bit as well as any parity, framing or overrun error or break status information related to the data is discarded.

---

FIGURE 3. NORMAL OPERATION RECEIVE DATA FORMAT

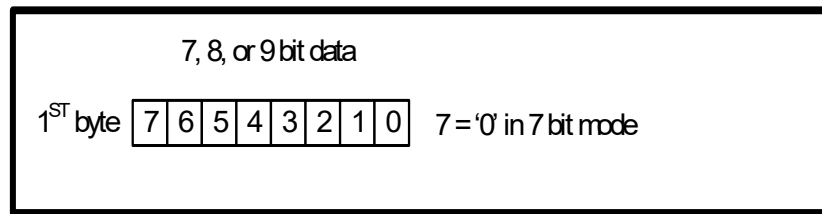

**1.5.2.3 Wide mode receive operation with 7 or 8-bit data**

Two bytes of data are loaded into the RX FIFO for each byte of data received. The first byte is the received data. The second byte consists of the error bits and break status. Wide mode receive data format is shown in Figure 4.

**1.5.2.4 Wide mode receive operation with 9-bit data**

Two bytes of data are loaded into the RX FIFO for each byte of data received. The first byte is the first 8 bits of the received data. The 9th bit received is stored in the bit 0 of the second byte. The parity bit is not received / checked. The remainder of the 2nd byte consists of the framing and overrun error bits and break status.

FIGURE 4. WIDE MODE RECEIVE DATA FORMAT

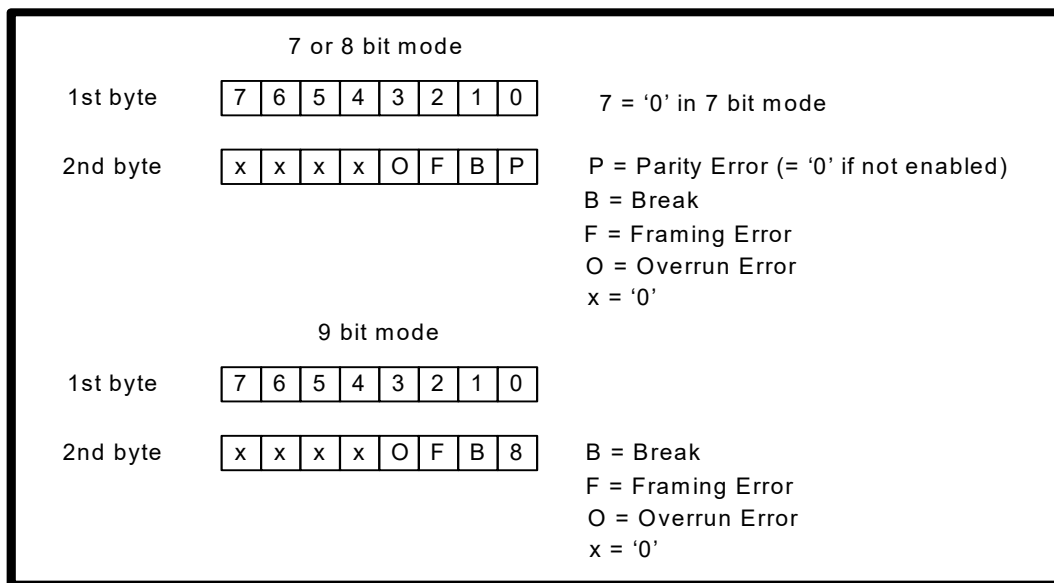

Error flags are also available from the ERROR\_STATUS register and the interrupt packet, however these flags are historical flags indicating that an error has occurred since the previous request. Therefore, no conclusion can be drawn as to which specific byte(s) may have contained an actual error in this manner.

**1.5.3 Rx FIFO Low Latency**

In normal operation all bulk-in transfers will be of maxPacketSize (64) bytes to improve throughput and to minimize host processing. When there are 64 bytes of data in the RX FIFO, the XR21V1410 will acknowledge a bulk-in request from the host and transfer the data packet. If there is less than 64 bytes in the RX FIFO, the XR21V1410 may NAK the bulk-in request indicating that data is not ready to transfer at that time. However, if there is less than 64 bytes in the RX FIFO and no data has been received for more than 3 character times, the XR21V1410 will acknowledge the bulk-in request and transfer any data in the RX FIFO to the USB host.

In some cases, especially when the baud rate is low, this increases latency unacceptably. The XR21V1410 has a low latency register bit that will cause the XR21V1410 to immediately transfer any received data in the



RX FIFO to the USB host, i.e. it will not wait for 3 character times. The custom driver can automatically set the RX\_FIFO\_LOW\_LATENCY register bit to force the XR21V1410 to be in the low latency mode, or the user may manually set this bit. With the CDC-ACM driver, the low latency mode is automatically set whenever the baud rate is set to a value of less than 46921 bps using the CDC\_ACM\_IF\_SET\_LINE\_CODING command.

**1.5.4 GPIO**

The UART has 6 GPIOs. By hardware default the GPIOs are configured as inputs but may be modified by a custom driver. Additionally, there are several modes that can be enabled to add additional feature such as auto RTS/CTS flow control, auto DTR/DSR flow control or auto RS-485 half duplex control. See Table 14.

**1.5.5 Automatic RTS/CTS Hardware Flow Control**

GPIO5 and GPIO4 of the UART channel can be enabled as the RTS# and CTS# signals for Auto RTS/CTS flow control when GPIO\_MODE[2:0] = '001' and FLOW\_CONTROL[2:0] = '001'. Automatic RTS flow control is used to prevent data overrun errors in local RX FIFO by de-asserting the RTS signal to the remote UART. When there is room in the RX FIFO, the RTS pin will be re-asserted. Automatic CTS flow control is used to prevent data overrun to the remote RX FIFO. The CTS# input is monitored to suspend/restart the local transmitter (see Figure 5):

**FIGURE 5. AUTO RTS AND CTS FLOW CONTROL OPERATION**

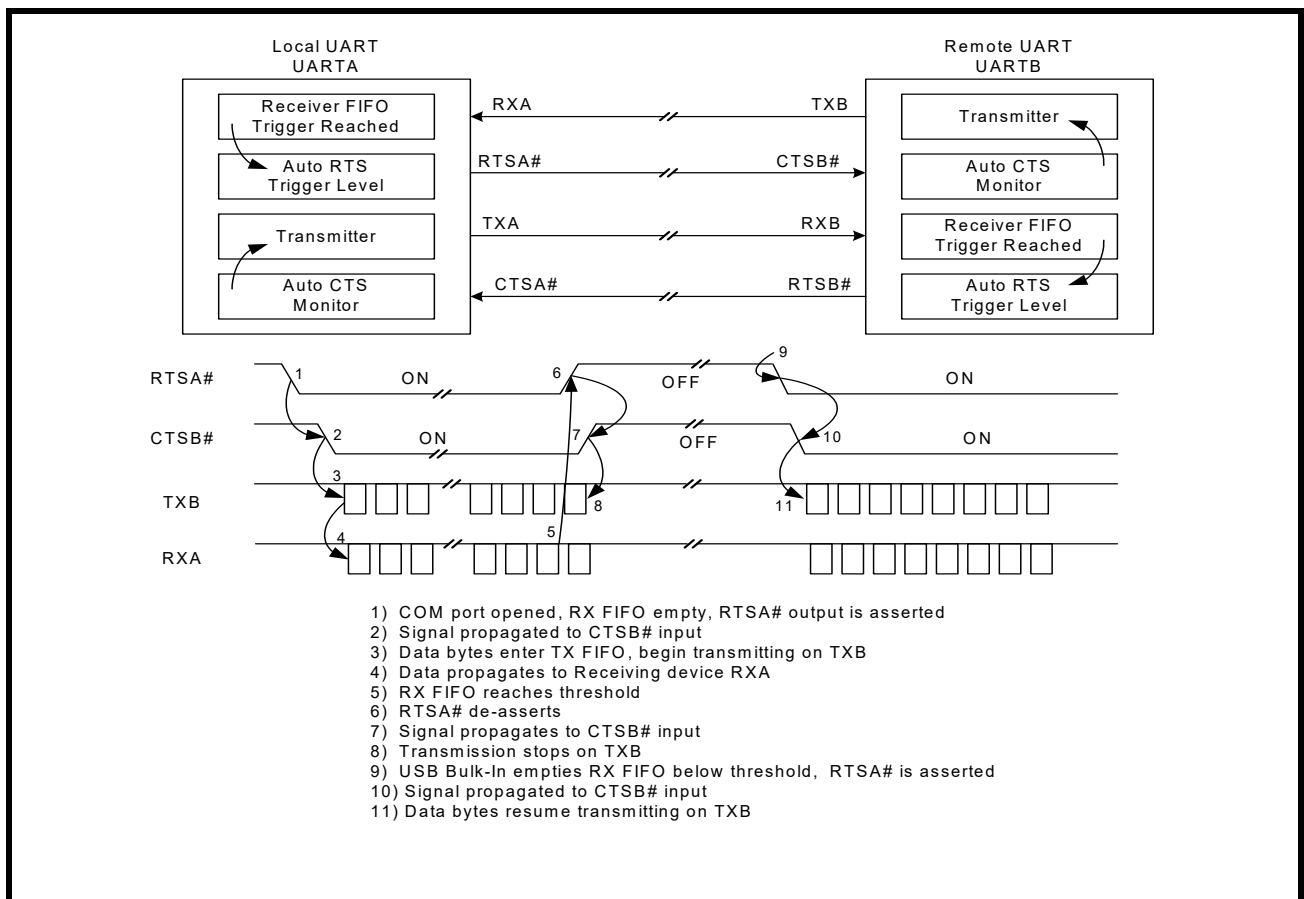

**1.5.6 Automatic DTR/DSR Hardware Flow Control**

Auto DTR/DSR hardware flow control behaves the same as the Auto RTS/CTS hardware flow control described above except that it uses the DTR# and DSR# signals. For Auto hardware flow control, FLOW\_CONTROL[2:0] = '001'. GPIO3 and GPIO2 become DTR# and DSR#, respectively, when GPIO\_MODE[2:0] = '010'.

### 1.5.7 Automatic XON/XOFF Software Flow Control

When software flow control is enabled, the XR21V1410 compares the receive data characters with the programmed Xon or Xoff characters. If the received character matches the programmed Xoff character, the XR21V1410 will halt transmission as soon as the current character has completed transmission. Data transmission is resumed when a received character matches the Xon character. Software flow control is enabled when `FLOW_CONTROL[2:0] = '010'`.

### 1.5.8 Auto RS-485 Half-Duplex Control

The Auto RS-485 Half-Duplex Control feature changes the behavior of the GPIO5/RTS#/RS485 pin when enabled by the GPIO\_MODE register bits 2-0. See "Section 3.3.12, GPIO\_MODE Register Description (Read/Write)" on page 22. The FLOW\_CONTROL register must also be set appropriately for use in multidrop applications. See "Section 3.3.6, FLOW\_CONTROL Register Description (Read/Write)" on page 19. If enabled, the transmitter automatically asserts the GPIO5/RTS#/RS485 output prior to sending the data. By default, it de-asserts GPIO5/RTS#/RS485 following the last stop bit of the last character that has been transmitted, but the RS485\_DELAY register may be used to delay the deassertion. The polarity of the GPIO5/RTS#/RS485 signal may also be modified using the GPIO\_MODE register bit 3.

### 1.5.9 Multidrop Mode with address matching

The XR21V1410 device has two address matching modes which are also set by the flow control register using modes 3 and 4. These modes are intended for a multi-drop network application. In these modes, the XON\_CHAR register holds a unicast address and the XOFF\_CHAR holds a multicast address. A unicast address is used by a transmitting master to broadcast an address to all attached slave devices that is intended for only one slave device. A multicast address is used to broadcast an address intended for more than one recipient device. Each attached slave device should have a unique unicast address value stored in the XON\_CHAR register, while multiple slaves may have the same multicast address stored in the XOFF\_CHAR register. An address match occurs when an address byte (9th bit or parity bit is '1') is received that matches the value stored in either the XON\_CHAR or XOFF\_CHAR register.

#### 1.5.9.1 Receiver

If an address match occurs in either flow control mode 3 or 4, the address byte will not be loaded into the RX FIFO, but all subsequent data bytes will be loaded into the RX FIFO. The UART Receiver will automatically be disabled when an address byte is received that does not match the values in the XON\_CHAR or XOFF\_CHAR register.

#### 1.5.9.2 Transmitter

In flow control mode 3, the UART transmitter is always enabled, irrespective of the Rx address match. In flow control mode 4, the UART transmitter will only be enabled if there is an Rx address match.

### 1.5.10 Programmable Turn-Around Delay

By default, the GPIO5/RTS#/RS485 pin will be de-asserted immediately after the stop bit of the last byte has been shifted when auto RS-485 half-duplex control is enabled by the GPIO\_MODE register. However, this may not be ideal for systems where the signal needs to propagate over long cables. Therefore, the de-assertion of GPIO5/RTS#/RS485 pin can be delayed from 1 to 15 bit times via the RS485\_DELAY register to allow for the data to reach distant UARTs.

### 1.5.11 Half-Duplex Mode

Half-duplex mode is enabled when `FLOW_CONTROL[3] = 1`. In this mode, the UART will ignore any data on the RX input when the UART is transmitting data.

### 1.5.12 USB Suspend

All USB peripheral devices must support the USB suspend mode. Per USB standard, the XR21V1410 device will begin to enter the Suspend state if it does not detect any activity (including Start of Frame or SOF packets) on its USB data lines for 3 ms. The device must then reduce power consumption from VBUS power within the next 7 ms to the allowed limit of 2.5 mA for the suspended state. Note that in this context, the "device" is all circuitry (including the XR21V1410) that draws power from the host VBUS.

### 1.5.13 Remote Wakeup

When the XR21V1410 is suspended, the GPIO0/RI#/RWK# pin can be used to request that the host exit the Suspend state. A high to low transition on this pin will cause the device to signal a remote wakeup request to the host via a custom driver. Note that the standard CDC-ACM driver does not support this feature. In order for the remote wakeup to work, several things must be properly configured. First, the GPIO0/RI#/RWK# pin must be configured as an input. Additionally, the XR21V1410 device must have the remote wakeup feature support indicated in the USB attributes - See [“Section 1.3, I2C Interface” on page 6](#). Lastly, a custom software driver must inform the USB host that the peripheral device supports the remote wake-up feature.

## 2.0 USB CONTROL COMMANDS

The following table shows all of the USB Control Commands that are supported by the XR21V1410. Commands included are standard USB commands, CDC-ACM commands and custom Exar commands.

**TABLE 4: SUPPORTED USB CONTROL COMMANDS**

NAME	REQUEST TYPE	REQUEST	VALUE		INDEX		LENGTH		DESCRIPTION
DEV_GET_STATUS	0x80	0	0	0	0	0	2	0	Device: remote wake-up + self-powered
IF_GET_STATUS	0x81	0	0	0	1-4, 129-132	0	2	0	Interface: zero
EP_GET_STATUS	0x82	0	0	0	0-4, 129-136	0	2	0	Endpoint: halted
DEV_CLEAR_FEATURE	0x00	1	1	0	0	0	0	0	Device remote wake-up
EP_CLEAR_FEATURE	0x02	1	0	0	0-4, 129-136	0	0	0	Endpoint halt
DEV_SET_FEATURE	0x00	3	1	00	0	0	0	0	Device remote wake-up
DEV_SET_FEATURE	0x00	3	2	0	0	test	0	0	Test mode
EP_SET_FEATURE	0x02	3	0	0	0-4, 129-136	0	0	0	Endpoint halt
SET_ADDRESS	0x00	5	addr	0	0	0	0	0	
GET_DESCRIPTOR	0x80	6	0	1	0	0	len LSB	len MSB	Device descriptor
GET_DESCRIPTOR	0x80	6	0	2	0	0	len LSB	len MSB	Configuration descriptor
GET_CONFIGURATION	0x80	8	0	0	0	0	1	0	
SET_CONFIGURATION	0x00	9	n	0	0	0	0	0	
GET_INTERFACE	0x81	10	0	0	0-7	0	1	0	
CDC_ACM_IF SET_LINE_CODING	0x21	32	0	0	0, 2, 4, 6	0	7	0	Set the UART baud rate, parity, stop bits, etc.
CDC_ACM_IF GET_LINE_CODING	0xA1	33	0	0	0, 2, 4, 6	0	7	0	Get the UART baud rate, parity, stop bits, etc.
CDC_ACM_IF SET_ CONTROL_LINE_ STATE	0x21	34	val	0	0, 2, 4, 6	0	0	0	Set UART control lines

**TABLE 4: SUPPORTED USB CONTROL COMMANDS**

NAME	REQUEST TYPE	REQUEST	VALUE		INDEX		LENGTH		DESCRIPTION
			val LSB	val MSB	0, 2, 4, 6	0	0	0	
CDC_ACM_IF SEND_BREAK	0x21	35	val LSB	val MSB	0, 2, 4, 6	0	0	0	Send a break for the specified duration
XR_SET_REG	0x40	0	val	0	regis- ter	block	0	0	Exar custom command: set one 8-bit register val: 8-bit register value register address: see <a href="#">Table 7</a> block number: see <a href="#">Table 5</a>
XR_GETN_REG	0xC0	1	0	0	regis- ter	block	count LSB	count MSB	Exar custom register: get count 8-bit registers register address: see <a href="#">Table 7</a> block number: see <a href="#">Table 5</a>

## 2.1 UART Block Numbers

The table below lists the block numbers for accessing each of the UART channels and the UART Manager.

**TABLE 5: CONTROL BLOCKS**

BLOCK NAME	BLOCK NUMBER	DESCRIPTION
UART	0	The configuration and control registers for the UART.
UART Manager	4	The control registers for the UART Manager. The UART Manager enables/disables the TX and RX FIFOs for each UART.
I2C EEPROM	0x65	Accesses external EEPROM via I2C interface.
UART Custom	0x66	Custom UART control registers. Enables / disables for wide mode, low latency mode and custom interrupt packet.

### 3.0 REGISTER SET DESCRIPTION

The internal register set of the XR21V1410 consists of 3 different blocks of registers: the UART Manager, UART registers and UART miscellaneous registers. The UART Manager controls the TX and RX enables and FIFOs of all UART channels. The UART registers configure and control the remaining UART channel functionality with the exception of low latency mode, wide mode and custom interrupt packet enables in the UART custom register block.

Registers are accessed only via the USB interface by the XR\_SET\_REG and XR\_GET\_REG commands listed in [Table 4](#). The register address offsets are given in [Table 6](#), [Table 7](#) and [Table 15](#), and the register blocks are given in [Table 5](#).

#### 3.1 UART Manager Registers

TABLE 6: UART MANAGER REGISTERS

ADDRESS	REGISTER NAME	BIT-7	BIT-6	BIT-5	BIT-4	BIT-3	BIT-2	BIT-1	BIT-0
0X10	FIFO_ENABLE	0	0	0	0	0	0	RX	TX
0X18	RX_FIFO_RESET	Bit-7	Bit-6	Bit-5	Bit-4	Bit-3	Bit-2	Bit-1	Bit-0
0x1C	TX_FIFO_RESET	Bit-7	Bit-6	Bit-5	Bit-4	Bit-3	Bit-2	Bit-1	Bit-0

##### 3.1.1 FIFO\_ENABLE Registers

Enables the RX FIFO and TX FIFOs. For proper functionality, the UART TX and RX must be enabled in the following order:

```
FIFO_ENABLE = 0x1      // Enable TX FIFO
UART_ENABLE = 0x3      // Enable TX and RX
FIFO_ENABLE = 0x3      // Enable RX FIFO
```

##### 3.1.2 RX\_FIFO\_RESET and TX\_FIFO\_RESET Registers

Writing a non-zero value to these registers resets the FIFOs.

**3.2 UART Register Map**
**TABLE 7: UART REGISTERS**

ADDRESS	REGISTER NAME	BIT-7	BIT-6	BIT-5	BIT-4	BIT-3	BIT-2	BIT-1	BIT-0
0X00	Reserved	0	0	0	0	0	0	0	0
0X01	Reserved	0	0	0	0	0	0	0	0
0X02	Reserved	0	0	0	0	0	0	0	0
0X03	UART_ENABLE	0	0	0	0	0	0	RX	TX
0X04	CLOCK_DIVISOR0	Bit-7	Bit-6	Bit-5	Bit-4	Bit-3	Bit-2	Bit-1	Bit-0
0x05	CLOCK_DIVISOR1	Bit-15	Bit-14	Bit-13	Bit-12	Bit-11	Bit-10	Bit-9	Bit-8
0x06	CLOCK_DIVISOR2	0	0	0	0	0	Bit-18	Bit-17	Bit-16
0x07	TX_CLOCK_MASK0	Bit-7	Bit-6	Bit-5	Bit-4	Bit-3	Bit-2	Bit-1	Bit-0
0x08	TX_CLOCK_MASK1	Bit-15	Bit-14	Bit-13	Bit-12	Bit-11	Bit-10	Bit-9	Bit-8
0x09	RX_CLOCK_MASK0	Bit-7	Bit-6	Bit-5	Bit-4	Bit-3	Bit-2	Bit-1	Bit-0
0x0A	RX_CLOCK_MASK1	Bit-15	Bit-14	Bit-13	Bit-12	Bit-11	Bit-10	Bit-9	Bit-8
0x0B	CHARACTER_FORMAT	Stop	Parity			Data Bits			
0x0C	FLOW_CONTROL	0	0	0	0	Half-Duplex	Flow Control Mode Select		
0x0D	Reserved	0	0	0	0	0	0	0	0
0x0E	Reserved	0	0	0	0	0	0	0	0
0x0F	Reserved	0	0	0	0	0	0	0	0
0x10	XON_CHAR	Bit-7	Bit-6	Bit-5	Bit-4	Bit-3	Bit-2	Bit-1	Bit-0
0x11	XOFF_CHAR	Bit-7	Bit-6	Bit-5	Bit-4	Bit-3	Bit-2	Bit-1	Bit-0
0x12	LOOPBACK_CTL	0	0	0	0	0	En	0	0
0x13	ERROR_STATUS	Break Status	Overrun Error	Parity Error	Framing Error	Break Error	0	0	0
0x14	TX_BREAK	Bit-7	Bit-6	Bit-5	Bit-4	Bit-3	Bit-2	Bit-1	Bit-0
0x15	RS485_DELAY	0	0	0	0	Delay			
0x16	Reserved	0	0	0	0	0	0	0	0
0x17	Reserved	0	0	0	0	0	0	0	0
0x18	Reserved	0	0	0	0	0	0	0	0
0x19	Reserved	0	0	0	0	0	0	0	0
0x1A	GPIO_MODE	0	0	0	0	RS485 Polarity	Mode Select		
0x1B	GPIO_DIRECTION	0	0	GPIO5	GPIO4	GPIO3	GPIO2	GPIO1	GPIO0
0x1C	GPIO_INT_MASK	0	0	GPIO5	GPIO4	GPIO3	GPIO2	GPIO1	GPIO0
0x1D	GPIO_SET	0	0	GPIO5	GPIO4	GPIO3	GPIO2	GPIO1	GPIO0
0x1E	GPIO_CLEAR	0	0	GPIO5	GPIO4	GPIO3	GPIO2	GPIO1	GPIO0
0x1F	GPIO_STATUS	0	0	GPIO5	GPIO4	GPIO3	GPIO2	GPIO1	GPIO0

### 3.3 *UART Register Descriptions*

All register bits default to a value of '0' unless otherwise noted.

#### 3.3.1 **UART\_ENABLE Register Description (Read/Write)**

This register enables the UART TX and RX. For proper functionality, the UART TX and RX must be enabled in the following order:

```
FIFO_ENABLE = 0x1      // Enable TX FIFO
UART_ENABLE = 0x3      // Enable TX and RX of that channel
FIFO_ENABLE = 0x3      // Enable RX FIFO
```

#### **UART\_ENABLE[0]: Enable UART TX**

- Logic 0 = UART TX disabled.
- Logic 1 = UART TX enabled.

#### **UART\_ENABLE[1]: Enable UART RX**

- Logic 0 = UART RX disabled.
- Logic 1 = UART RX enabled.

#### **UART\_ENABLE[7:2]: Reserved**

These bits are reserved and should remain '0'.

#### 3.3.2 **CLOCK\_DIVISOR0, CLOCK\_DIVISOR1, CLOCK\_DIVISOR2 Register Description (Read/Write)**

These registers are used for programming the baud rate. The XR21V1410 uses a 19-bit divisor and 16-bit mask register. Using the internal 48MHz oscillator, the 19-bit divisor is calculated as follows:

$$\text{CLOCK\_DIVISOR} = \text{Trunc} ( 48000000 / \text{Baud Rate} )$$

For example, if the the baud rate is 115200bps, then

$$\text{CLOCK\_DIVISOR} = \text{Trunc} ( 48000000 / 115200 ) = \text{Trunc} (416.66667) = 416$$

#### **CLOCK\_DIVISOR0[7:0]: Baud rate clock divisor bits [7:0]**

#### **CLOCK\_DIVISOR1[7:0]: Baud rate clock divisor bits [15:8]**

#### **CLOCK\_DIVISOR2[2:0]: Baud rate clock divisor bits [18:16]**

#### **CLOCK\_DIVISOR2[7:3]: Reserved**

These bits are reserved and should remain '0'.

#### 3.3.3 **TX\_CLOCK\_MASK0, TX\_CLOCK\_MASK1 Register Description (Read/Write)**

A look-up table is used for the value of the 16-bit TX Clock mask registers. The index of the look-up table is calculated as follows:

$$\text{index} = \text{Trunc} ( ( ( 48000000 / \text{Baud Rate} ) - \text{CLOCK\_DIVISOR} ) * 32 )$$

For example, if the baud rate is 115200bps, then the index will be:

$$\text{index} = \text{Trunc} ( ( ( 48000000 / 115200 ) - 416 ) * 32 ) = \text{Trunc} (21.3333) = 21$$

The values for some baud rates to program the TX\_CLOCK\_MASK registers are listed in [Table 8](#). For baud rates that are not listed, use the index to select TX\_CLOCK\_MASK register values from [Table 9](#).

#### 3.3.4 **RX\_CLOCK\_MASK0, RX\_CLOCK\_MASK1 Register Description (Read/Write)**

The values for some example baud rates to program the RX\_CLOCK\_MASK registers are listed in [Table 8](#). For baud rates that are not listed, use the same index calculated for the TX\_CLOCK\_MASK register to select RX\_CLOCK\_MASK register values from [Table 9](#).



**TABLE 8: CLOCK DIVISOR AND CLOCK MASK VALUES FOR COMMON BAUD RATES**

BAUD RATE (BPS)	CLOCK DIVISOR (DECIMAL)	TX CLOCK MASK (HEX)	RX CLOCK MASK (HEX)
1200	40000	0x0000	0x0000
2400	20000	0x0000	0x0000
4800	10000	0x0000	0x0000
9600	5000	0x0000	0x0000
19200	2500	0x0000	0x0000
38400	1250	0x0000	0x0000
57600	833	0x0912	0x0924
115200	416	0x0B6D	0x0B6A
230400	208	0x0912	0x0924
460800	104	0x0208	0x0040
500000	96	0x0000	0x0000
576000	83	0x0912	0x0924
921600	52	0x0040	0x0000
1000000	48	0x0000	0x0000
1152000	41	0x0B6D	0x0DB6
1500000	32	0x0000	0x0000
2000000	24	0x0000	0x0000
2500000	19	0x0104	0x0108
3000000	16	0x0000	0x0000
3125000	15	0x0492	0x0492
3500000	13	0x076D	0x0BB6
4000000	12	0x0000	0x0000
4250000	11	0x0122	0x0224
6250000	7	0x0B6D	0x0DB6
8000000	6	0x0000	0x0000
12000000	4	0x0000	0x0000

For baud rates that are not listed in the table above, use the index value calculated using the formula in “[Section 3.3.3, TX\\_CLOCK\\_MASK0, TX\\_CLOCK\\_MASK1 Register Description \(Read/Write\)](#)” on page 16 to determine which TX Clock and RX Clock Mask register values to use from [Table 9](#). For the the RX Clock Mask register, there are 2 values listed and would depend on whether the Clock Divisor is even or odd. For even Clock Divisors, use the value from the first column. For odd Clock Divisors, use the value from the last column.

TABLE 9: TX AND RX CLOCK MASK VALUES

INDEX (DECIMAL)	TX CLOCK MASK (HEX)	RX CLOCK MASK (HEX) - EVEN CLOCK DIVISOR	RX CLOCK MASK (HEX) - ODD CLOCK DIVISOR
0	0x0000	0x0000	0x0000
1	0x0000	0x0000	0x0000
2	0x0100	0x0000	0x0100
3	0x0020	0x0400	0x0020
4	0x0010	0x0100	0x0010
5	0x0208	0x0040	0x0208
6	0x0104	0x0820	0x0108
7	0x0844	0x0210	0x0884
8	0x0444	0x0110	0x0444
9	0x0122	0x0888	0x0224
10	0x0912	0x0448	0x0924
11	0x0492	0x0248	0x0492
12	0x0252	0x0928	0x0292
13	0x094A	0x04A4	0x0A52
14	0x052A	0x0AA4	0x054A
15	0x0AAA	0x0954	0x04AA
16	0x0AAA	0x0554	0x0AAA
17	0x0555	0x0AD4	0x05AA
18	0x0B55	0x0AB4	0x055A
19	0x06B5	0x05AC	0x0B56
20	0x05B5	0x0D6C	0x06D6
21	0x0B6D	0x0B6A	0x0DB6
22	0x076D	0x06DA	0x0BB6
23	0x0EDD	0x0DDA	0x076E
24	0x0DDD	0x0BBA	0x0EEE
25	0x07BB	0x0F7A	0x0DDE
26	0x0F7B	0x0EF6	0x07DE
27	0x0DF7	0x0BF6	0x0F7E
28	0x07F7	0x0FEE	0x0EFE
29	0x0FDF	0x0FBE	0x07FE
30	0x0F7F	0x0EFE	0x0FFE
31	0x0FFF	0x0FFE	0x0FFD

### 3.3.5 CHARACTER\_FORMAT Register Description (Read/Write)

This register controls the character format such as the word length (7, 8 or 9), parity (odd, even, forced '0', or forced '1') and number of stop bits (1 or 2).

**CHARACTER\_FORMAT[3:0]: Data Bits.**

**TABLE 10: DATA BITS**

DATA BITS	CHARACTER_FORMAT[3:0]
7	0111
8	1000
9	1001

All other values for CHARACTER\_FORMAT[3:0] are reserved.

**CHARACTER\_FORMAT[6:4]: Parity Mode Select**

These bits select the parity mode. If 9-bit data mode has been selected, then writing to these bits will not have any effect. In other words, there will not be an additional parity bit.

**TABLE 11: PARITY SELECTION**

BIT-6	BIT-5	BIT-4	PARITY SELECTION
0	0	0	No parity
0	0	1	Odd parity
0	1	0	Even parity
0	1	1	Force parity to mark, "1"
1	0	0	Force parity to space, "0"

**CHARACTER\_FORMAT[7]: Stop Bit select**

This register selects the number of stop bits to add to the transmitted character and how many stop bits to check for in the received character.

**TABLE 12: STOP BIT SELECTION**

BIT-7	NUMBER OF STOP BITS
0	1 stop bit
2	2 stop bits

### 3.3.6 FLOW\_CONTROL Register Description (Read/Write)

These registers select the flow control mode. These registers should only be written to when the UART is disabled. Writing to the FLOW\_CONTROL register when the UART is enabled will result in undefined behavior. Note that the FLOW\_CONTROL register settings are used in conjunction with the GPIO\_MODE register.

**FLOW\_CONTROL[2:0]: Flow control mode select****TABLE 13: FLOW CONTROL MODE SELECTION**

MODE	BIT-2	BIT-1	BIT-0	MODE DESCRIPTION
0	0	0	0	No flow control, no address matching.
1	0	0	1	HW flow control enabled. Auto RTS/CTS or DTR/DSR must be selected by GPIO_MODE.
2	0	1	0	SW flow control enabled
3	0	1	1	Multidrop mode - RX only after address match, TX independent. (Typically used with GPIO_MODE 3)
4	1	0	0	Multidrop mode - RX / TX only after address match. (Typically used with GPIO_MODE 4)

**FLOW\_CONTROL[3]: Half-Duplex Mode**

- Logic 0 = Normal (full-duplex) mode. The UART can transmit and receive data at the same time.
- Logic 1 = Half-duplex Mode. In half-duplex mode, any data on the RX pin is ignored when the UART is transmitting data.

**FLOW\_CONTROL[7:4]: Reserved**

These bits are reserved and should remain '0'.

**3.3.7 XON\_CHAR, XOFF\_CHAR Register Descriptions (Read/Write)**

The XON\_CHAR and XOFF\_CHAR registers store the XON and XOFF characters, respectively, that are used in the Automatic Software Flow control. If the XR21V1410 is configured in multidrop mode, the XON\_CHAR and XOFF\_CHAR registers are instead used for address matching.

**XON\_CHAR[7:0]: XON Character**

In Automatic Software Flow control mode, the UART will resume data transmission when the XON character has been received.

For behavior in the Address Match mode, see [“Section 1.5.9, Multidrop Mode with address matching” on page 10.](#)

**XOFF\_CHAR[7:0]: XOFF Character**

In Automatic Software Flow control mode, the UART will suspend data transmission when the XOFF character has been received.

For behavior in the Address Match mode, see [“Section 1.5.9, Multidrop Mode with address matching” on page 10.](#)

**3.3.8 LOOPBACK\_CTL Register Descriptions (Read/Write)****LOOPBACK\_CTL[1:0]: Reserved**

These bits are reserved and should remain '0'.

**LOOPBACK\_CTL[2]: Enable**

- Logic 0 = Internal UART (TX to RX) loopback is disabled.
- Logic 1 = Internal UART (TX to RX) loopback is enabled.

**LOOPBACK\_CTL[7:3]: Reserved**

These bits are reserved and should remain '0'.

### 3.3.9 ERROR\_STATUS Register Description - Read-only

This register reports any errors that may have occurred on the line such as framing, parity and overrun as well as break status.

#### ERROR\_STATUS[2:0]: Reserved

These bits are reserved. Any values read from these bits should be ignored.

#### ERROR\_STATUS[3]: Break status

- Logic 0 = No break condition
- Logic 1 = A break condition has been detected (clears after read).

#### ERROR\_STATUS[4]: Framing Error

- Logic 0 = No framing error
- Logic 1 = A framing error has been detected (clears after read). A framing error occurs when a stop bit is not present when it is expected.

#### ERROR\_STATUS[5]: Parity Error

- Logic 0 = No parity error
- Logic 1 = A parity error has been detected (clears after read).

#### ERROR\_STATUS[6]: Overrun Error

- Logic 0 = No overrun error
- Logic 1 = An overrun error has been detected (clears after read). An overrun error occurs when the RX FIFO is full and another byte of data is received.

#### ERROR\_STATUS[7]: Break Status

- Logic 0 = Break condition is no longer present.
- Logic 1 = Break condition is currently being detected.

### 3.3.10 TX\_BREAK Register Description (Read/Write)

Writing a non-zero value to this register causes a break condition to be generated continuously until the register is cleared. If data is being shifted out of the TX pin, the data will be completely shifted out before the break condition is generated.

### 3.3.11 RS485\_DELAY Register Description (Read/Write)

#### RS485\_DELAY[3:0]: Turn-around delay

This is the number of bit times the XR21V1410 waits before de-asserting the GPIO5/RTS#/RS485 pin when it is configured for automatic RS-485 half-duplex control.

#### RS485\_DELAY[7:4]: Reserved

These bits are reserved and should be '0'.

### 3.3.12 GPIO\_MODE Register Description (Read/Write)

#### GPIO\_MODE[2:0]: GPIO Mode Select

There are 4 modes of operation for the GPIOs. The descriptions can be found in “Section 1.5, UART” on page 7.

TABLE 14: GPIO MODES

BITS [2:0]	GPIO0	GPIO1	GPIO2	GPIO3	GPIO4	GPIO5	MODE DESCRIPTION
000	GPIO0	GPIO1	GPIO2	GPIO3	GPIO4	GPIO5	GPIO Mode, All GPIO pins available as GPIO
001	GPIO0	GPIO1	GPIO2	GPIO3	CTS#	RTS#	GPIO4 and GPIO5 used for Auto RTS/CTS HW Flow Control
010	GPIO0	GPIO1	DSR#	DTR#	GPIO4	GPIO5	GPIO2 and GPIO3 used for Auto DTR/DSR HW Flow Control
011	GPIO0	GPIO1	GPIO2	GPIO3	GPIO4	RS485	GPIO5 used for auto RS-485 half-duplex control
100	GPIO0	GPIO1	GPIO2	GPIO3	GPIO4	RS485	GPIO5 used for auto RS-485 half-duplex control after address match (See FLOW_CONTROL mode 4).

#### GPIO\_MODE[3]: RS485 Polarity

- Logic 0 = GPIO5/RTS#/RS485 Low for TX
- Logic 1 = GPIO5/RTS#/RS485 High for TX

#### GPIO\_MODE[7:4]: Reserved

These register bits are reserved. When writing to these bits, the value should be '0'. When reading from these bits, they are undefined and should be ignored.

### 3.3.13 GPIO\_DIRECTION Register Description (Read/Write)

This register controls the direction of pins configured as GPIO. (Pins configured for UART functions via the GPIO\_MODE register, e.g. RTS# are not controlled or reported in the GPIO\_DIRECTION register.)

#### GPIO\_DIRECTION[5:0]: GPIOx Direction

- Logic 0 = GPIOx is an input.
- Logic 1 = GPIOx is an output.

#### GPIO\_DIRECTION[7:6]: Reserved

These register bits are reserved and should be '0'.

### 3.3.14 GPIO\_INT\_MASK Register Description (Read/Write)

Enables / disables generation of a USB interrupt packet at the change of state of GPIO pins when they are configured as inputs.

#### GPIO\_INT\_MASK[5:0]: GPIOx Interrupt Mask

- Logic 0 = A change on this input does not cause the device to generate an interrupt packet.
- Logic 1 = A change on this input causes the device to generate an interrupt packet.

#### GPIO\_INT\_MASK[7:6]: Reserved

These register bits are reserved and should be '0'.

### 3.3.15 GPIO\_SET Register Description (Read/Write)

Writing a '1' to the corresponding GPIO bit (5:0) of this register drives the GPIO output high. Writing a '0' to a bit has no effect. Bits 7-6 are unused and should be '0'.

### 3.3.16 GPIO\_CLEAR Register Description (Read/Write)

Writing a '1' to the corresponding GPIO bit (5:0) of this register drives the GPIO output low. Writing a '0' to a bit has no effect. Bits 7-6 are unused and should be '0'.

### 3.3.17 GPIO\_STATUS Register Description (Read-Only)

This register reports the current state of the GPIO pin.

## 3.4 UART Custom Registers

**TABLE 15: UART CUSTOM REGISTERS**

ADDRESS	REGISTER NAME	BIT-7	BIT-6	BIT-5	BIT-4	BIT-3	BIT-2	BIT-1	BIT-0
0X03	CUSTOM	0	0	0	0	0	0	MaxPkt-Size	WIDE_En
0x04	LOW_LATENCY	0	0	0	0	0	0	0	EN
0x06	CUSTOM_INT_PACKET	0	GPIO5	GPIO4	GPIO3	GPIO0	0	GPIO2	GPIO1

### 3.4.1 CUSTOM Register Description (Read/Write)

This register controls the bMaxPacketSize and enables the Wide mode functionality for the UART.

#### CUSTOM[0]: Enable wide mode

- Logic 0 = Normal (7, 8 or 9 bit data) mode
- Logic 1 = Wide mode - See [“Section 1.5.1.1, Wide Mode Transmit”](#) on page 7, [“Section 1.5.2.3, Wide mode receive operation with 7 or 8-bit data”](#) on page 8 and [“Section 1.5.2.4, Wide mode receive operation with 9-bit data”](#) on page 8.

#### CUSTOM[1]: Max Packet Size

- Logic 0 = bMaxPacketSize = 64 bytes
- Logic 1 = bMaxPacketSize = 63 bytes (this bit is automatically set to '1' if the XR21V1410 receives a CDC\_ACM USB command)

#### CUSTOM[7:2]: Reserved

These bits are reserved and should remain '0'

### 3.4.2 LOW\_LATENCY Register Description (Read/Write)

This register is automatically set to logic '1' for baud rates below 46921 bps, and can be manually set for baud rates of 46921 bps and higher. This register enables the Low latency feature of the UART. Write to this register following any desired baud rate setting change.

#### LOW\_LATENCY[0]: Enable Low Latency mode

- Logic 0 = Receive data is not forwarded from the Rx FIFO until bMaxPacketSize (64 bytes) or timeout (3 characters) has occurred.
- Logic 1 = All data in the RX FIFO is provided to the USB host at the next BULK IN request irrespective of the number of bytes in the FIFO.

#### LOW\_LATENCY[7:1]: Reserved

These bits are reserved and should remain '0'.

**XR21V1410****1-CH FULL-SPEED USB UART**

---

**3.4.3 CUSTOM\_INT\_PACKET (Read/Write)**

This register is used to enable / disable GPIO status in the high data byte of the custom interrupt packet. See [Table 16, "Interrupt Packet Format," on page 25](#) and [Table 18, "Data Field of Customized Interrupt Packet - Exar Vendor Specific," on page 26](#).

**CUSTOM\_INT\_PACKET[0]: GPIO1**

- Logic 0 = Disable GPIO1 status in custom interrupt packet.
- Logic 1 = Enable GPIO1 status in custom interrupt packet.

**CUSTOM\_INT\_PACKET[1]: GPIO2**

- Logic 0 = Disable GPIO2 status in custom interrupt packet.
- Logic 1 = Enable GPIO2 status in custom interrupt packet.

**CUSTOM\_INT\_PACKET[2]: Reserved**

- This bit is reserved and should remain '0'.

**CUSTOM\_INT\_PACKET[3]: GPIO0**

- Logic 0 = Disable GPIO0 status in custom interrupt packet.
- Logic 1 = Enable GPIO0 status in custom interrupt packet.

**CUSTOM\_INT\_PACKET[4]: GPIO3**

- Logic 0 = Disable GPIO3 status in custom interrupt packet.
- Logic 1 = Enable GPIO3 status in custom interrupt packet.

**CUSTOM\_INT\_PACKET[5]: GPIO4**

- Logic 0 = Disable GPIO4 status in custom interrupt packet.
- Logic 1 = Enable GPIO4 status in custom interrupt packet.

**CUSTOM\_INT\_PACKET[6]: GPIO5**

- Logic 0 = Disable GPIO5 status in custom interrupt packet.
- Logic 1 = Enable GPIO5 status in custom interrupt packet.

**CUSTOM\_INT\_PACKET[7]: Reserved**

This bit is reserved and should remain '0'.



**TABLE 16: INTERRUPT PACKET FORMAT**

OFFSET	FIELD	SIZE (BYTES)	VALUE	DESCRIPTION
0	bmRequestType	1	8'b10100001	D7 = Device-to-host direction D6:5 = Class Type D4-0: = Interface Recipient
1	bNotification	1	8'h20	Defined encoding for SERIAL_STATE
2	wValue	2	16'h0000	
4	wIndex	2	16'h0000	D15-8 = Reserved (0) D7-0 = Interface number, 8'h00 for the CDC Command Interface
6	wLength	2	16'h0002	2 bytes of transferred data
8	Data	2	Standard int_status (See Table 17 or Table 18)	D15-7 = Reserved (0) D6 = bOverRun D5 = bParity D4 = bFraming D3 = bRingSignal (RI) D2 = bBreak D1 = bTxCarrier (DSR) D0 = bRxCarrier (CD)

**TABLE 17: DATA FIELD OF STANDARD INTERRUPT PACKET**

BIT(s)	FIELD	DESCRIPTION
D15..D7		Reserved (0)
D6	bOverRun	Received data has been discarded due to overrun in the device.
D5	bParity	A parity error has occurred.
D4	bFraming	A framing error has occurred.
D3	bRingSignal	State of ring signal detection of the device.
D2	bBreak	State of break detection mechanism of the device.
D1	bTxCarrier	State of transmission carrier. This signal corresponds to V.24 signal 106 and RS-232 signal DSR.
D0	bRxCarrier	State of receiver carrier detection mechanism of device. This signal corresponds to V.24 signal 109 and RS-232 signal DCD.

If the Exar vendor specific packet mapping is enabled then the data field also includes status for all of the UART / GPIO pins as follows:

**TABLE 18: DATA FIELD OF CUSTOMIZED INTERRUPT PACKET - EXAR VENDOR SPECIFIC**

<b>BIT(s)</b>	<b>FIELD</b>	<b>DESCRIPTION</b>
15	D15	Reserved (0)
14	D14	bGPIO5 (RTS)
13	D13	bGPIO4 (CTS)
12	D12	bGPIO3 (DTR)
11	D11	bGPIO0 (RI)
10	D10	Reserved (0)
9	D9	bGPIO2 (DSR)
8	D8	bGPIO1 (CD)
7	D7	Reserved (0)
6	D6	bOverRun
5	D5	bParity
4	D4	bFraming
3	D3	bRingSignal (RI)
2	D2	bBreak
1	D1	bTxCarrier (DSR)
0	D0	bRxCarrier (CD)

**4.0 ELECTRICAL CHARACTERISTICS**
**TABLE 19: ABSOLUTE MAXIMUM RATINGS**

PARAMETER	RATING	UNIT
V <sub>CC</sub> Supply Voltage	+ 4.0	V
Input Voltage (all pins except USBD+ and USBD-)	- 0.3 to + 6.0	V
Input Voltage (USBD+ and USBD-)	- 0.3 to + 5.75	V
Junction Temperature	125	°C

**DC ELECTRICAL CHARACTERISTICS - POWER CONSUMPTION**

 UNLESS OTHERWISE NOTED: T<sub>A</sub> = -40° TO +85°C, V<sub>CC</sub> IS 2.97 TO 3.63V

SYMBOL	PARAMETER	LIMITS 3.3V			UNITS	CONDITIONS
		MIN	TYP	MAX		
I <sub>CC</sub>	Power Supply Current		16	20	mA	
I <sub>Susp</sub>	Suspend mode Current		1.5	1.65	mA	

**DC ELECTRICAL CHARACTERISTICS - UART, LOWPOWER & GPIO PINS**

 UNLESS OTHERWISE NOTED: T<sub>A</sub> = -40° TO +85°C, V<sub>CC</sub> IS 2.97 TO 3.63V

SYMBOL	PARAMETER	LIMITS 3.3V		UNITS	CONDITIONS
		MIN	MAX		
V <sub>IL</sub>	Input Low Voltage	-0.3	0.8	V	
V <sub>IH</sub>	Input High Voltage	2.0	5.5	V	
V <sub>OL</sub>	Output Low Voltage		0.3	V	I <sub>OL</sub> = 4mA
V <sub>OH</sub>	Output High Voltage	2.2		V	I <sub>OH</sub> = -4mA
I <sub>IL</sub>	Input Low Leakage Current		±10	uA	
I <sub>IH</sub>	Input High Leakage Current		±10	uA	
C <sub>IN</sub>	Input Pin Capacitance		5	pF	

**DC ELECTRICAL CHARACTERISTICS - USB I/O PINS**UNLESS OTHERWISE NOTED:  $T_A = -40^{\circ}$  TO  $+85^{\circ}\text{C}$ ,  $V_{CC}$  IS 2.97 TO 3.63V

SYMBOL	PARAMETER	LIMITS 3.3V		UNITS	CONDITIONS
		MIN	MAX		
$V_{IL}$	Input Low Voltage	-0.3	0.8	V	
$V_{IH}$	Input High Voltage	2.0	5.5	V	
$V_{OL}$	Output Low Voltage	0	0.3	V	External 15 KOhm to GND on USB D- pin
$V_{OH}$	Output High Voltage	2.8	3.6	V	External 15 KOhm to GND on USB D- pin
$V_{DRVZ}$	Driver Output Impedance	28	44	Ohms	
$I_{OSC}$	Open short current Current		38.5	mA	1.5 V on USB D+ and USB D-

**MECHANICAL DIMENSIONS (16 PIN QFN - 3 X 3 X 0.9 mm)**

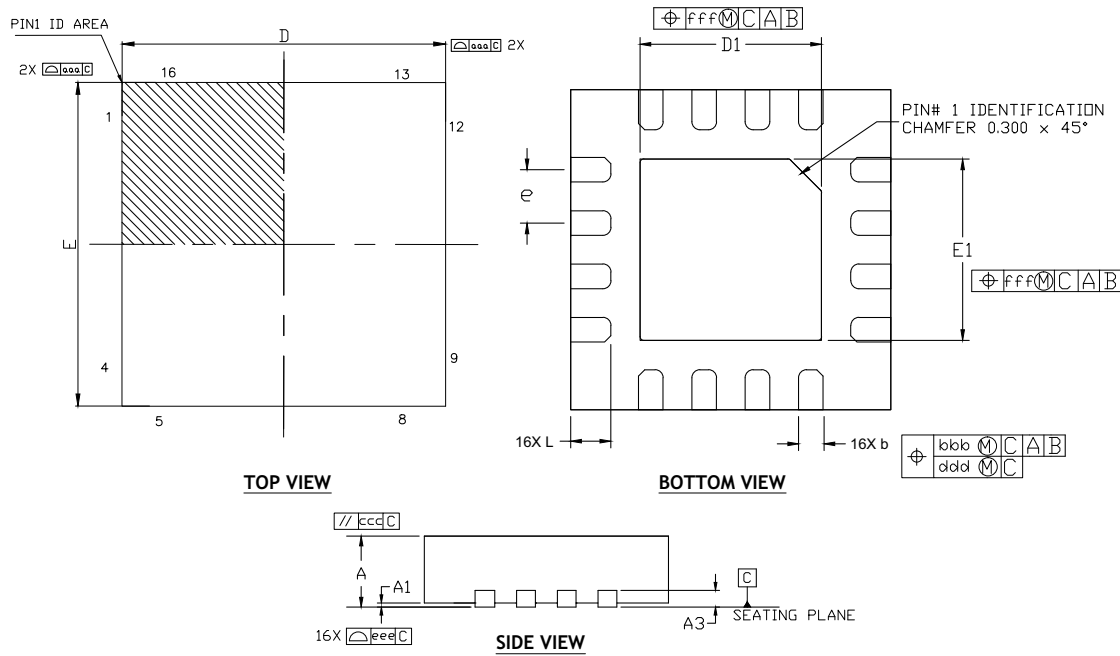

DIMENSION TABLE			
SYMBOL	MIN	NOM	MAX
A	0.80	0.90	1.00
A1	0.00	0.02	0.05
A3	0.20Ref		
b	0.18	0.25	0.30
D	3.00 BSC		
E	3.00 BSC		
e	0.50 BSC		
D1	1.50	1.65	1.80
E1	1.50	1.65	1.80
L	0.20	0.30	0.40
K	0.20	-	-
aaa		0.15	
bbb		0.10	
ccc		0.10	
ddd		0.05	
eee		0.08	
fff		0.10	
N		16	

**TERMINAL DETAILS**

- ALL DIMENSIONS ARE IN MILLIMETERS.
- DIMENSIONS AND TOLERANCE PER JEDEC MO-220.

Drawing No.: POD-00000138

Revision: A

**NOTE:** QFN16  $\theta_{JA} = 36.4^{\circ}\text{C/W}$ ,  $\theta_{JC} = 17.8^{\circ}\text{C/W}$ . All values are typical.

**RECOMMENDED LAND PATTERN AND STENCIL**

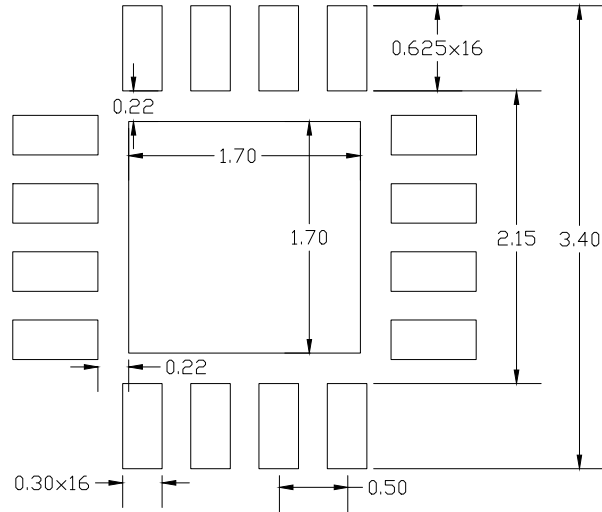

**TYPICAL RECOMMENDED LAND PATTERN**

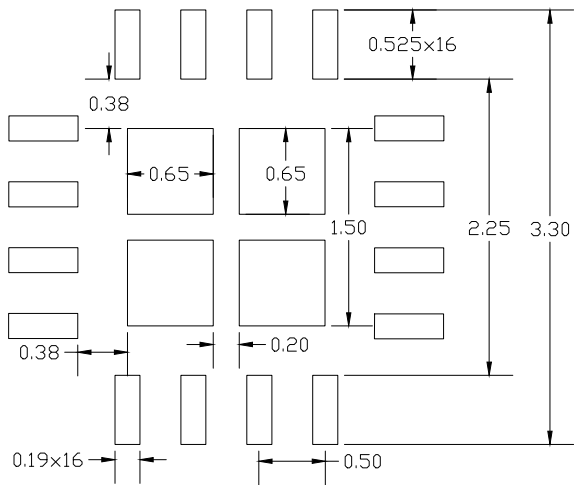

**TYPICAL RECOMMENDED STENCIL**

Drawing No.: POD- 00000138

Revision: A

**REVISION HISTORY**

DATE	REVISION	DESCRIPTION
June 2009	1.0.0	Released Datasheet
September 2010	1.1.0	Clarified pin functionality, wide mode and low latency mode including registers / blocks, clarified FLOW_CONTROL and GPIO_MODE register functionality.
April 2011	1.2.0	Updated ordering information, SDA/SCL pin types, modified GPIO0 pin name and added LOOPBACK_CTL register and description.
April 2012	1.3.0	Updated LOWPOWER pin description, bMaxPacketSize and DC electrical characteristics. See PCN12-0305-01 for more details.
July 2013	1.3.1	Updated package drawing QFN16
January 2014	1.4.0	Added Windows driver versions, added absolute maximum tables, added ESD protection ratings, added QFN package center pad to pin descriptions, minor clarifications including requirement for even Product ID in Windows OS. Updated package drawing.
June 2018	1.4.1	Updated to MaxLinear logo. Updated format and Ordering Information. Removed Windows 2000, removed IR mode from Tx and Rx pins. GPIO_INT_MASK register logic updated. Updated all "V1410" to XR21V1410. Updated last paragraph of General Description. Updated GPIO_SET and GPIO_CLEAR Register Descriptions.

**Corporate Headquarters:**

5966 La Place Court  
 Suite 100  
 Carlsbad, CA 92008  
 Tel.: +1 (760) 692-0711  
 Fax: +1 (760) 444-8598  
[www.maxlinear.com](http://www.maxlinear.com)

**High Performance Analog:**

1060 Rincon Circle  
 San Jose, CA 95131  
 Tel.: +1 (669) 265-6100  
 Fax: +1 (669) 265-6101  
[www.exar.com](http://www.exar.com)

The content of this document is furnished for informational use only, is subject to change without notice, and should not be construed as a commitment by MaxLinear, Inc.. MaxLinear, Inc. assumes no responsibility or liability for any errors or inaccuracies that may appear in the informational content contained on this guide. Complying with all applicable copyright laws is the responsibility of the user.. Without limiting the rights under copyright, no part of this document may be reproduced into, stored in, or introduced into a retrieval system, or transmitted in any form or by any means (electronic, mechanical, photocopying, recording, or otherwise), or for any purpose, without the express written permission of MaxLinear, Inc.

MaxLinear, Inc. does not recommend the use of any of its products in life support applications where the failure or malfunction of the product can reasonably be expected to cause failure of the life support system or to significantly affect its safety or effectiveness. Products are not authorized for use in such applications unless MaxLinear, Inc. receives, in writing, assurances to its satisfaction that: (a) the risk of injury or damage has been minimized; (b) the user assumes all such risks; (c) potential liability of MaxLinear, Inc. is adequately protected under the circumstances.

MaxLinear, Inc. may have patents, patent applications, trademarks, copyrights, or other intellectual property rights covering subject matter in this document. Except as expressly provided in any written license agreement from MaxLinear, Inc., the furnishing of this document does not give you any license to these patents, trademarks, copyrights, or other intellectual property.

Company and product names may be registered trademarks or trademarks of the respective owners with which they are associated.

© 2014 - 2018 MaxLinear, Inc. All rights reserved.